

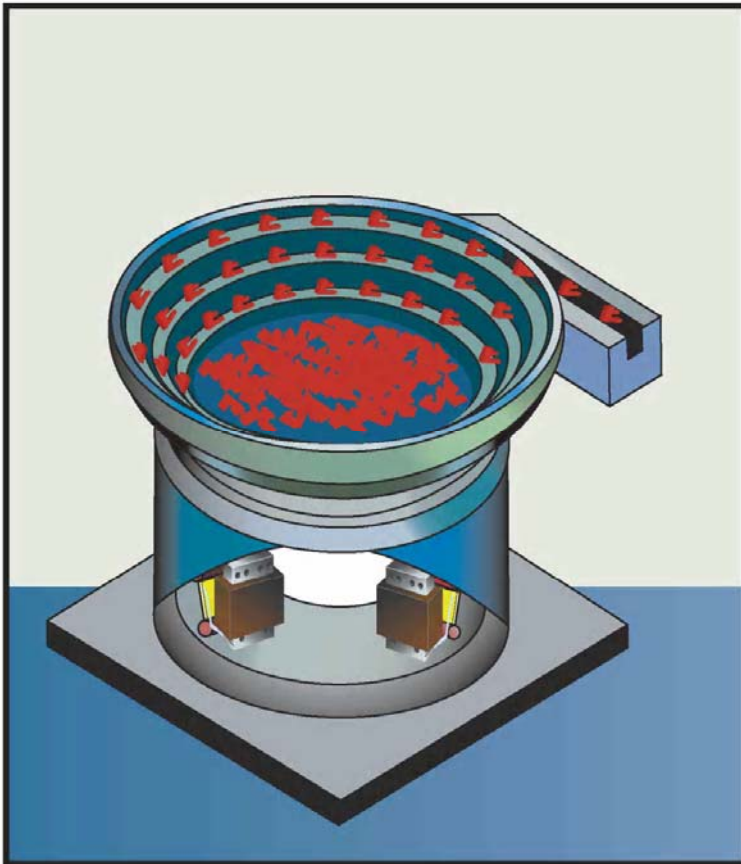

## REOVIB MFS 168 Microprocessor Frequency System



- Voltage compensation
- Suitable for 110 V and 240 V supplies
- Internal setpoint using display, external with potentiometer
- Enable input 24 VDC or contact
- Adjustable frequency range of 30...140 Hz
- Sinusoidal output current
- Automatic optimum frequency search
- Operation via LED display and keypad
- Start/Stop keys for the feeder in the touch panel
- Memory storage for user settings
- All settings can be made without opening the unit
- Integrated track control and amplitude regulation

REO-USA, Inc.  
3250 North Post Road, Suite 132  
Indianapolis, IN 46226  
Phone (317) 899-1395 Fax (317) 899-1396  
Website: [www.reo-usa.com](http://www.reo-usa.com) Email: [info@reo-usa.com](mailto:info@reo-usa.com)

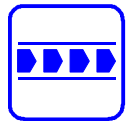

# REOVIB MFS 168

## Microprocessor Frequency System

The REOVIB MFS 168 series of variable frequency regulators is specially designed for maintaining constant feed rate under various load conditions. The units produce a highly stable output frequency that is adjustable in 0.1 Hz increments. Manual “tuning” the mechanical feed system is significantly reduced. With the sinusoidal output, the feeder runs quietly and ensures gentle product handling.

Settings are adjusted by using a touch panel and an integrated digital display. The feed rate setpoint can be adjusted externally in several ways, including the use of 0...10 V or 0(4)...20 mA signals. One set of user parameters can be stored and recalled. The unit is also available with integrated track control and amplitude feedback.

Electrical connections are made via input/output power cables.

|  |  |
|--|--|
| Type                                   | REOVIB MFS 168   |
| ID NR.:                                | 616748   |
| Supply voltage:                        | 110 V, 240 V, ±10 %, 50/60 Hz  |
| Output frequency:                      | 30...140 Hz  |
| Output voltage:                        | 0...95 V, 0...205 V  |
| Output current:                        | 8A   |
| Setpoint:                              | Internal using display<br>External with 0...+10 VDC,<br>0(4)...20 mA or<br>potentiometer 10 kΩ |
| Enable signal:                         | 24 VDC or contact  |
| Status relay:                          | Changeover contact 250 V, 1 A  |
| Track control:<br>(optional)           | Internal power supply 24 VDC<br>for PNP sensor   |
| Amplitude<br>regulation:<br>(optional) | sensor connection:<br>REOVIB SW 11   |
| Operating<br>temperature:              | 0...+45 °C   |
| Protection class:                      | IP 54  |

