

Flat Braking Resistors

100 – 250 W, DB / 1 – 2.5 kW, KB

REOHM

Series BW 150

Type BW 154/...

Lying flat or Standing on edge design

Applications:

Braking resistors for variable frequency drives. Inverters and drive motors with a dynamic load that requires quick stopping.

- Elevators
- Cranes
- High speed machines

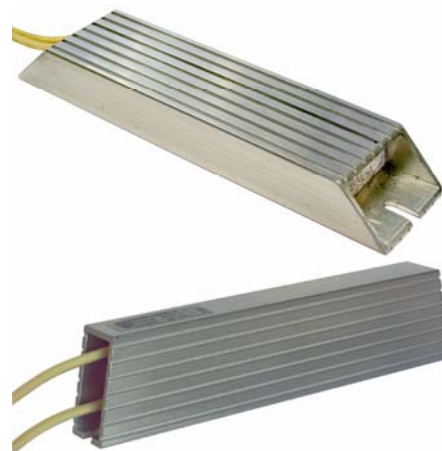

Protection IP 20	Test voltage 2,5 kV AC
Max. Temp > 300 °C	Ambient temperature -10...+40 °C

Circuit example

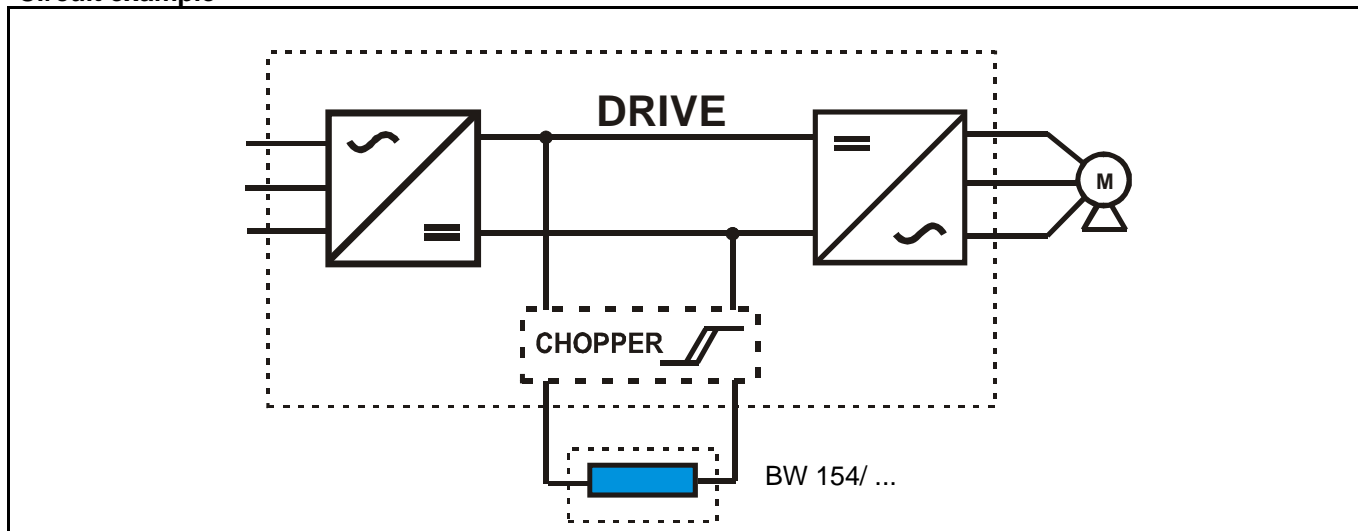

Benefits:

- Decelerating a load with large inertia
- Increase the control torque of the inverter
- For frequently repeated ON/OFF cycles
- Compact construction
- Easy installation
- Suitable for the use with any frequency drive
- Compact design
- Continuous power: Max. 2.5kw
- Protection
- Dielectric strength
- High temperature wire
- CE Marked
- DIN 41 480 compliant

Technical data

Type	Resistance values R [Ohm]	Continuous power P [W]	Max. Operating voltage U [V]
BW 154 / 100 / .../L	25 - 1600	100	900
BW 154 / 150 / .../L	30 - 1000	150	900
BW 154 / 200 / .../L	40 - 350	200	900
BW 154 / 250 / .../L	50 - 300	250	900
BW 154 / 100 / .../S	25 - 1600	100	900
BW 154 / 150 / .../S	30 - 1000	150	900
BW 154 / 200 / .../S	40 - 350	200	900
BW 154 / 250 / .../S	50 - 300	250	900

Other power ratings on request

	<p>Maximum energy with minimum space.</p> <p>This unit is very compact with high power.</p> <p>Suitable for IP 65 applications without fan assembled.</p> <p>Capacity can be doubled by fan that is provided, IP 20 protection.</p>	
--	--------------------------------------------------------------------------------------------------------------------------------------------------------------------------------------------------------------------------------------------	--

Load diagram

$$P_{\max} = \frac{P * 100}{ED[\%]}$$

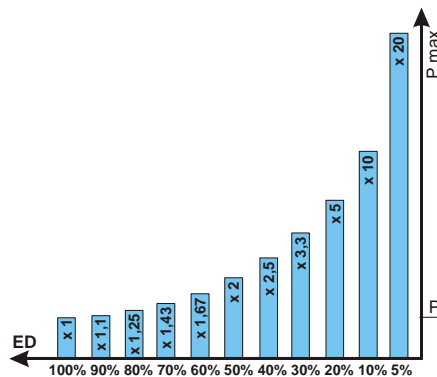

SD = Cycle time max 120 sec.

$$ED[\%] = \frac{ED[s]}{SD[s]} * 100$$

ED = Duty cycle

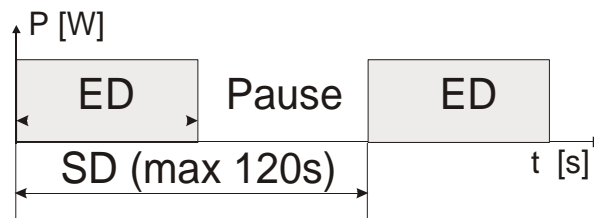

Dimension Drawing

Lying Flat Versions

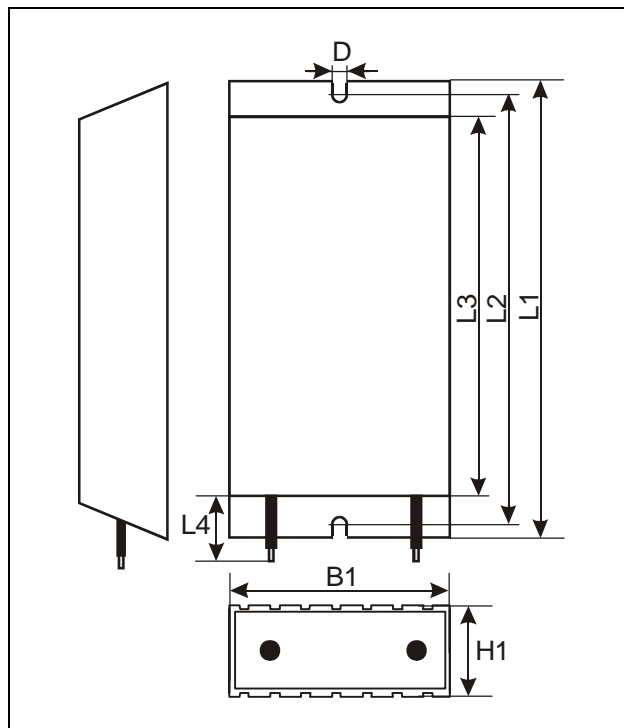

Standing on Edge Version

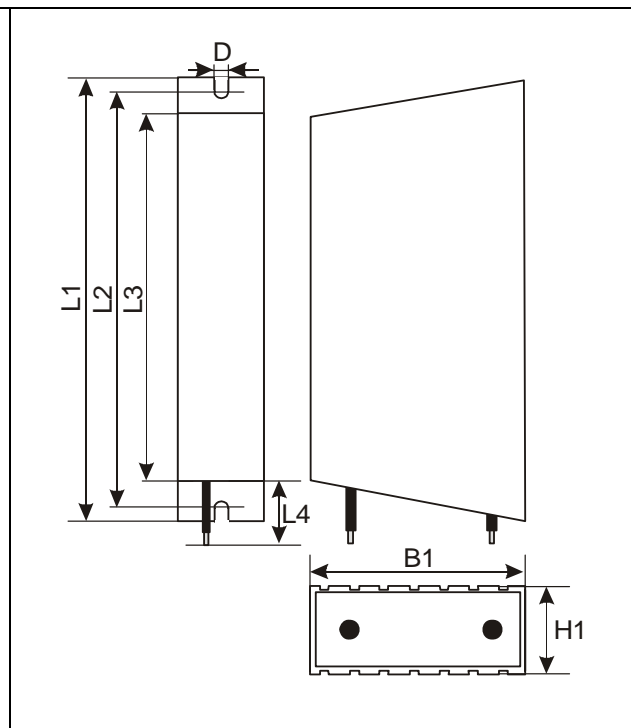

Type	B1	H1	L1	L2	L3	L4	D	Connection cable
	[mm]	[mm]	[mm]	[mm]	[mm]	[mm]	[mm]	
BW 154 / 100 / .../ L	40	21	170	155	140	250	5.5	2 x AWG 14, UL 1659
BW 154 / 150 / .../ L	40	21	210	195	180	250	5.5	2 x AWG 14, UL 1659
BW 154 / 200 / .../ L	40	21	250	235	220	250	5.5	2 x AWG 14, UL 1659
BW 154 / 250 / .../ L	40	21	290	275	260	250	5.5	2 x AWG 14, UL 1659
BW 154 / 100 / .../ S	40	21	170	155	140	250	5.5	2 x AWG 14, UL 1659
BW 154 / 150 / .../ S	40	21	210	195	180	250	5.5	2 x AWG 14, UL 1659
BW 154 / 200 / .../ S	40	21	250	235	220	250	5.5	2 x AWG 14, UL 1659
BW 154 / 250 / .../ S	40	21	290	275	260	250	5.5	2 x AWG 14, UL 1659

Custom mounting positions are available upon request