

Footprint Braking Resistors

up to 600 W, DB / 6 kW, KB

REOHM Series BW 400
Type BW 402/...

Applications:

Braking resistors are used with inverters, driving motors with a dynamic load that requires to be stopped quickly such as lifts, cranes or high-speed mechanisms.

The braking resistor is connected in the DC link, between the rectifier and the switching semiconductors. When the DC voltage rises, to a pre-selected limit, a chopper circuit switches in the braking resistor thereby allowing excess energy to be “dumped” in the form of heat, instead of causing damage to the inverter.

When the DC level drops to a lower preset minimum limit the braking resistor is switched out of circuit until it is required again.



Protection IP 20	Test voltage 4.0 kV DC 1s
Max. temperature 250 °C	Ambient temperature -10...+40 °C

Circuit example

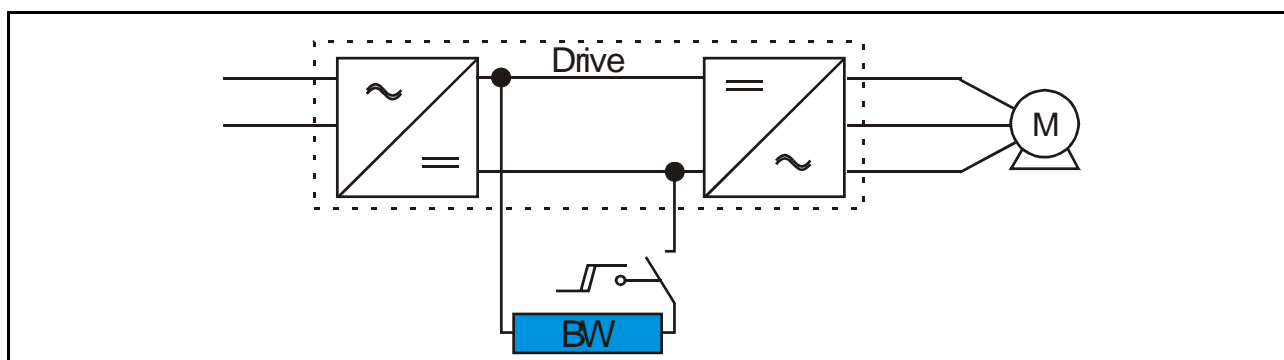

Benefits:

- Decelerating a load with large inertia
- Increase the control torque of the inverter
- For frequently repeated ON/OFF cycles
- Compact construction
- Easy installation
- Suitable for the use with any frequency drive
- Compact design
- Continuous power: Max. 600W
- High temperature wire
- CE Marked
- DIN 41 480 compliant

Technical data

Type	Resistance values [Ohm]	Continuous power [W]	Max. Operating voltage [V]
BW 402/100/...	30 - 2000	100	900
BW 402/200/...	22 - 1200	200	900
BW 402/300/...	21 - 1000	300	900
BW 402/400/...	20 - 900	400	900
BW 402/600/...	18 - 650	600	900

Other power ratings on request

Dynamics without extra floor space

Especially with retrofitting or use of several drive, there is often a problem of sufficient floor space in switch cabinets in order to meet all requirements.

It is possible to mount the REO footprint braking resistor under the drive and make it almost disappear.

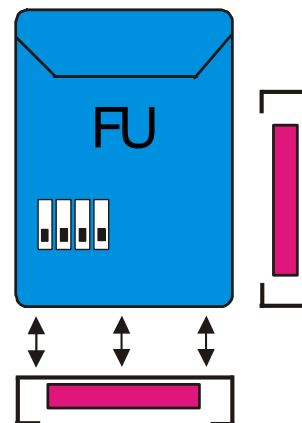

Power Rating Calculation

A braking resistor is selected according to the systems duty cycle requirements. If the resistor is not being used continuously then it can be used for a higher power rating because it has time to cool during the "rest" period. To calculate, the following formula is used:

$$P_{max} = \frac{P \times 100}{ED [\%]}$$

$$ED\% = \frac{ED[s]}{SD[s]} \times 100$$

Where ED = Duty Cycle
SD = Cycle time

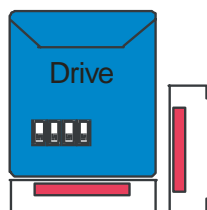
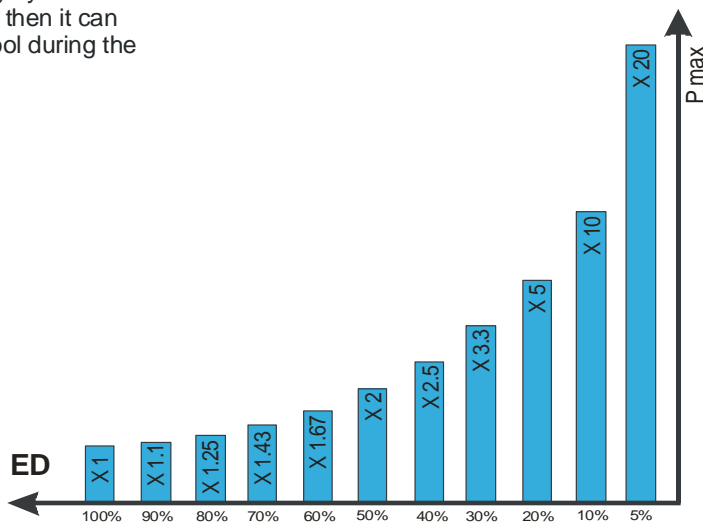
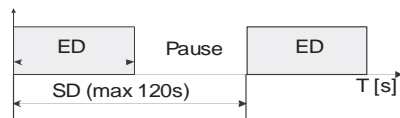

REO-USA, Inc. can offer virtually any braking resistor design to suit any frequency drive, with optional mounting methods: such as footprint, book style, or compact. The footprint version is particularly useful for retrofit applications because no extra panel space is required. Most constructions are in a modular form that is easy to install.

Additional forced air cooling can be fitted to some versions and this greatly increases their power rating, or alternatively enables use within a confined space, such as an IP65 enclosure for food quality or clean room applications.

Type	L (mm)	B (mm)	H (mm)	La 1 (mm)	La 2 (mm)	Ldm (mm)	Connection cable
BW 402/100/...	260	110	30	250	212	5.5	2xAWG 18 UL 1659
BW 402/200/...	260	110	30	250	212	5.5	2xAWG 18 UL 1659
BW 402/300/...	281	120	48	101	270	5.5	2xAWG 18 UL 1659
BW 402/400/...	281	120	48	101	270	5.5	2xAWG 18 UL 1659
BW 402/600/...	331	120	48	101	317	5.5	2xAWG 18 UL 1659

Other fixing dimensions possible

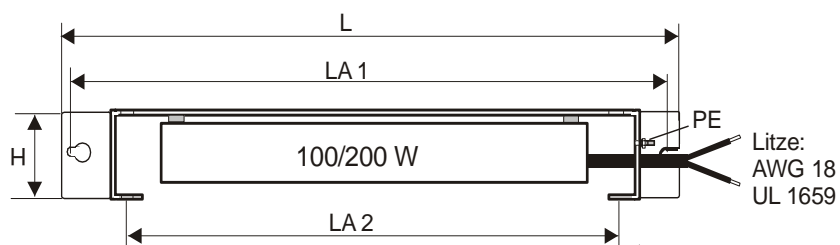

Montageblech :Stahl verzinkt

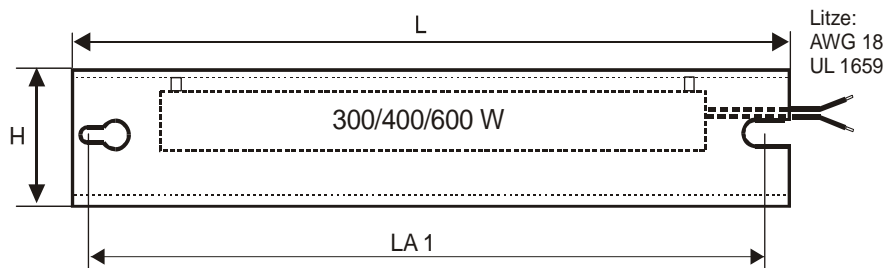
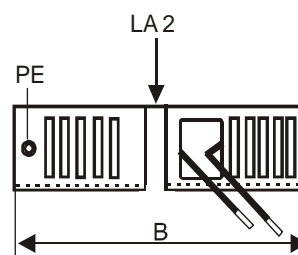

Montageblech :Aluminium

