



Operating Instructions
VAREOSOFT SAG M300
Soft Starters for AC motors
With current limiting

REO-USA, Inc.
3250 North Post Road, Suite 132
Indianapolis, IN 46226
USA
Phone (317) 899-1395
Fax (317) 899-1396
Web site www.reo-usa.com
Email info@reo-usa.com

VAREOSOFT

Control units for the drive industry

Technical safety information for the user

This description contains the necessary information for the correct application of the product described below. It is intended for use by technically qualified personal.

Qualified personnel are persons who, because of their training, experience and position as well as their knowledge of appropriate standards, regulations, health and safety requirements and working conditions, are authorized to be responsible for the safety of the equipment, at all times, whilst carrying out their normal duties and are therefore aware of, and can report, possible hazards (Definition of qualified employees according to IEC 364)

Safety Instructions

The following instructions are provided for the personal safety of operators and also for the protection of the described product and connected equipment.



Warning!

Hazardous Voltage

Failure to observe can kill, cause serious injury or damage

- Isolate from mains before installation or dismantling work, as well as for fuse changes or post installation modifications.
- Observe the prescribed accident prevention and safety rules for the specific application.
- Before putting into operation check if the rated voltage for the unit conforms to the local supply voltage.
- Emergency stop devices must be provided for all applications. Operation of the emergency stop must inhibit any further uncontrolled operation.
- **The electrical connecting terminals must be covered!**
- **Earth bonding must be tested for integrity after installation.**

Specified Use

The units described herein are electrical controllers for installation in industrial plant. They are designed for controlling motors.

Contents

Technical safety information for the user	1
Contents	1
1.0 General	2
2.0 Function	2
2.1 Operating principles of 3 and 6 - Wire Circuits (W3 Circuit)	2
3.0 Technical Data	3
3.1 Conformance statement	3
4.0 System planning	4
4.1 Cross-sectional area of conductors	4
4.2 Fuses	4
5.0 Installation	4
5.1 Preparatory checks	4
5.2 Settings	4
5.3 Determination of starting current	5
6.0 Setting controls:	6
7.0 Displays	7
8.0 Settings	7
8.1 Display peak current value (in % of I _{max})	7
8.2 Save parameter settings	8
8.3 Recall parameters	8
9.0 Connections	9
10.0 Dimensions / views	11

1.0 General

The VAREOTRON SAG M300 series of soft start units have been designed for the starting of AC motors, connected in 3 or 6 wire (root 3) configuration, by current limiting. The current limit is set between 1 and 4 times the rated current and during the ramp up phase the active regulator maintains this limit, thereby reducing surges on the supply. The ramp up time can be determined by the starting current setting (for minimum duration) and can also be extended by a separate ramp up time setting. Additionally, the ramp down time can also be controlled. The starting current setting is expressed as a percentage of the maximum current adjustment. A front-panel LED and three programming keys are provided for setting up the unit. All parameters adjustments can be made by using the touch-panel.

Start-up is initiated by the use of closing contacts or by applying 24 VDC. In very simple systems, start and enable links are fitted and the mains supply is switched on. An internal, "top of ramp" relay is energized after completion of the start up sequence, to indicate that the running speed has been reached. This relay could, for example, control a by-pass contactor. A settable, restart time delay (0...30 sec) can be used with equipment that has a demanding start-up duty, such as air conditioning plant or compressors. A changeover contact provides warning of thermal overloading of the controller.

2.0 Function

The start up current is limited by reducing the motor voltage using phase-angle control. The instantaneous current is determined by measuring the motor current, in one phase, and this is fed back to the regulation circuit. The firing angle of the thyristors is controlled from the regulation circuit, to give the required current limit. As soon as the output voltage reaches its full rating (zero phase-angle), the "top of ramp" relay closes. The change-over contacts are brought out to terminals 7, 8 and 9 for use with an interlocking circuit or a by-pass contactor.

The units are designed to handle the rated motor power (maximum motor power) and a maximum adjustable start-up current (equipment peak voltage). The required starting current is set as a percentage of the maximum equipment current (100%). The motor runs at this current limit until it reaches running speed. If no additional start-up, ramp time is selected, then the run-up to speed is achieved in the shortest possible time. An enable input can be used for interlocking with other equipment but when this is not used a link must be fitted between terminals 1 and 2.

The Start/Stop input initiates the run-up and run-down sequences.

When the restart inhibit is activated, a new run-up sequence cannot commence until the time delay has expired. An automatic restart will occur after the elapsed time delay if the start signal is present.

2.1 Operating principles of 3 and 6 - Wire Circuits (W3 Circuit)

The soft start unit is located between the main isolator and the motor.

When a 6-wire circuit (also known as W3 circuit) is used, only 56% of the rated motor current flows through the soft start unit. Therefore, a higher powered motor can be controlled (see technical data table). This circuit comprises a delta circuit with thyristors connected in series to the motor windings. The only disadvantage of this method is that more cable is required because of the 6-wire connection.

To use W3 connection the parameter 6.CO must be set to = 1 in user menu C002.

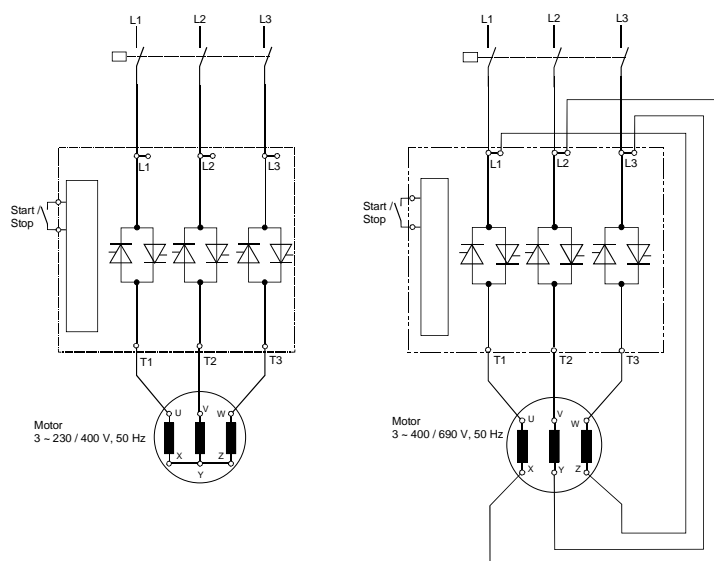

3.0 Technical Data

Model No. SAG M300	11	23	32	45	63	75		
Rated Supply voltage	3 x 380...415 V -10 / + 10 % 50 / 60 Hz							
Motor power for 3-wire connection [KW]	7,5	11	18,5	22	30	37		
Motor power for 6-wire connection (W3 configuration) [KW]	11	22	30	37	45	55		
Current rating [A]	15,2	21,7	36	41	55	68		
Cable cross-sectional area inside a panel [mm ²]	2,5	6	10	16	25	35		
Cable cross-sectional area outside a panel [mm ²]	2,5	4	10	10	16	25		
Earth leakage trip [A] NHgl/gG, 500 V, 100 kA Dgl/gG, 500 V, 50 kA	16	25	40	50	63	80		
Semiconductor fuse (optional) [A]	80 A	100 A	125 A	160 A	250 A	350 A		
Maximum starting current (adjustable 0...100 %) [A]	0...4 x I rated							
Start / h	60, ED 20 Sec. (30%)							
Ramp-up time	0...25 Seconds (adjustable)							
Ramp-down time	0...25 Seconds (adjustable)							
Starting torque	0...100 % (adjustable)							
Restart time delay	0...30 Seconds							
Fault relay	Changeover 250 V, 1 A (AC)							
Top of ramp – Relay	Changeover 250 V, 1 A (AC)							
Construction	IP 00							
Contact protection	VBG 4							
Operating temperature	0...45 °C							
Storage temperature	-20...+70 °C							
Relative humidity	93 % without condensation or dew							
Environmental conditions	Grade 1 (IEC 664)							
Altitude	1000 m 0,5 % Current rating reduction for each additional 100 m							
Mounting orientation	Vertical							

3.1 Conformance statement

These units conform to the low voltage standard EN 60947-4-2: 1996 Part 2:
Semiconductor controllers and starters for AC: IEC 947-4-2: 1995.

We confirm that these products conform to the following standards or guidelines:
EN 50081-1 und EN 50082-2 in accordance with directive 89/336/EWG.



REO ELEKTRONIK GMBH, D-42657 Solingen

4.0 System planning

The units are designed for vertical mounting within a panel.

A clearance of at least 10cm, above and below the unit, should be left to allow cooling air to circulate.

The conductor and motor protection devices should be sized according to the motor power rating.

Power factor correction capacitors should only be connected on the input side of the soft start unit.

4.1 Cross-sectional area of conductors

The conductors should have the correct cross-sectional area as specified in the relevant standards for panel installations and motors.

4.2 Fuses

It is recommended that semiconductor fuses are used for the most effective protecting the soft start unit (see values in technical data table). The employment of semiconductor fuses will protect against damage through a short-circuit on the output side of the unit. At the very least, the normal protective devices for motors and earth leakage should be fitted.

5.0 Installation

Safety guidelines

The unit should be installed by qualified Persons only.



There is an earth leakage current to the ground plane (PE) from RFI capacitors (Y capacitors). Therefore the controller **must** be earthed.

After switching off the power supply, approximately 5 minutes must be allowed for the storage capacitors to discharge, before carrying out any work on the connection terminals.

5.1 Preparatory checks

- Check that the unit's rating plate voltage is the same as the local power supply and that power rating is sufficient for the motor to be connected.
- Connect the unit according to the wiring diagram.
- Close the enable (when it is used).
- Check that the cables have been correctly connected.

The control unit is now basically ready to run and can be switched on (Mains, Enable).

5.2 Settings

The factory settings can be found in the following table:

Parameter:		Code	Factory setting:	Access Code:
• Starting voltage (starting torque)	0...100 %	U.	0 %	002
• Start current	0...100 %	I.	100%	002
• Ramp-up time	0...25 Sec.	/	0,1 Sec	002
• Run-down time	0...25 Sec.	\	0,1 Sec	002
• 3 or 6 wire (W3) configuration	0 / 1	6.CO.	0	002
• Peak current (run-up peak)	% of I _{max}	I-.		005
• Restart delay	0...30 Sec.	H.	0	002
• Save parameter settings		PUSH		143
• Recall saved parameters		US.PA		210
• Recall factory settings		FAC.		210

Starting voltage: The starting voltage can be set to > 0 to overcome the initial resistance of the mechanical system, which provides a steady and safe run up of the motor.

Starting current: Over current during start-up (See section 5.3 for more details).

Ramp up time: When a ramp up time is used, in addition to current limiting, this can be set for up to 25 seconds duration.

Run-down time: When the motor can not be stopped quickly, as in the case of a pump, the run-down time can be set for up to 25 seconds duration.

This operates only in conjunction with the stop/start input.

Peak current display: The percentage of the motor peak current can be monitored, to help with setting the start-up current, when this is selected in the menu.

Restart inhibit: The motor cannot be restarted during the set time (0...30 seconds). The motor starts automatically after the time has elapsed if the start signal remains applied.

Save parameter settings: The current settings can be saved and recalled, for example after making trial adjustments.

Recall saved parameters and factory settings: Previously saved and factory settings can be recalled by this means.

5.3 Determination of starting current

The soft start unit has a current limit value (equipment peak current) which determines the maximum allowable run-up current. The starting current is expressed as percentage of this maximum current.

$$I - Start = \frac{I_{rated} \cdot K}{I_{max}} \quad (K = \text{Current increase factor from } I_{rated})$$

The factory setting is 100% of the maximum allowable current. It should be possible to use this value for a provisional setup.

The correct relationship between the soft start unit and motor is a maximum start-up current of approximately 4 times the motor current.

Example:

Motor = 11 KW, $I_{Rated} = \sim 21,7A$

Soft start unit MSGA 23

Maximum possible start up current = 92 A

Desired start-up current = $1,5 \times I_{Rated}$ ($K = 1.5$)

$$I - Start = 100 \cdot \frac{21,7 \cdot 1,5}{92} = 35,3$$

Displayed setting = 35,3 %

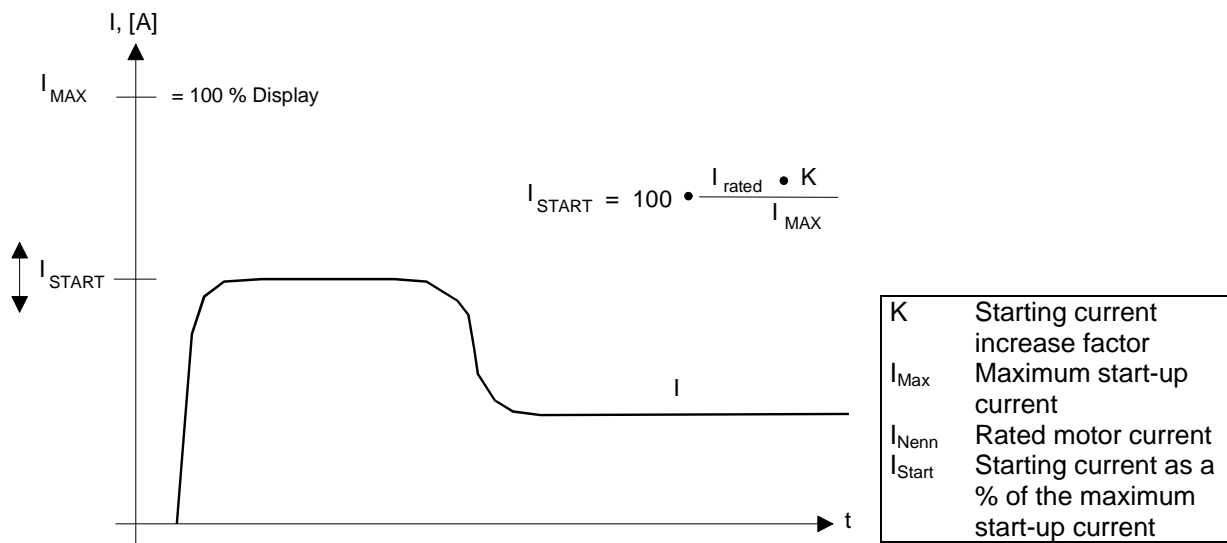

6.0 Setting controls:

The three buttons and a LED display found in the front panel are used for setting up the unit. All adjustable parameters can be set up through this panel. Parameters are set by using menu controls which are called up by entering operator codes.

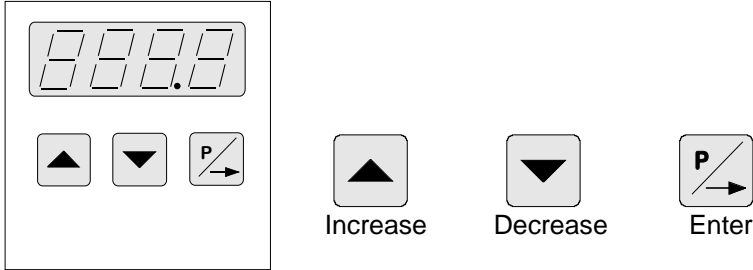

The display value can be increased or decreased by units, or tenths of units, by a short press of the cursor buttons. Holding the buttons down will cause the display to change in units of ten.

To prevent accidental or unauthorized adjustment the adjustment parameters, in the user menus, are protected. A code must be entered to open the user menus. There are different pass codes for each function group.

Setting adjustments are automatically saved upon leaving the programming mode or if no button is pressed for a period of 30 seconds

All setting routines are commenced by pressing the programming button “P”. The following diagram should clarify the sequence in which keys are pressed:-

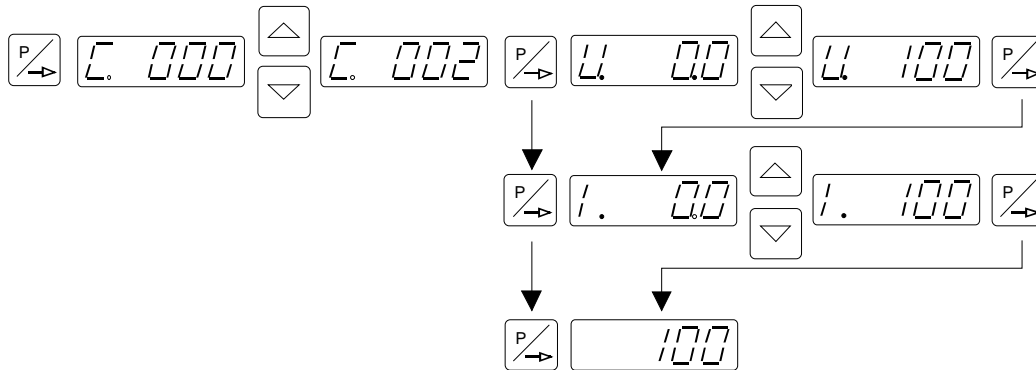

1. Press the “P” key.
2. Select the code number with the cursor keys.
3. Press the “P” key. This displays the first menu point. The required menu point can be found by repeatedly pressing the “P” key (scrolling).
4. The value in the menu point can be changed with the cursor keys.
5. Scroll to the next menu point or to the end of the menu, which returns the display to the set point value, by pressing the “P” key. To exit the menu and return back to the normal display.

During normal running 100% is displayed (completion of run-up).

7.0 Displays

During run-up and run-down the control value is displayed in %.

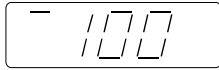

Display after completion of run-up.

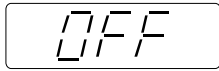

Faulty enable display.

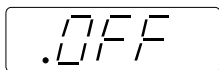

Flashing dot in the first segment indicates that the restart, time delay is running.



8.0 Settings

Code 002

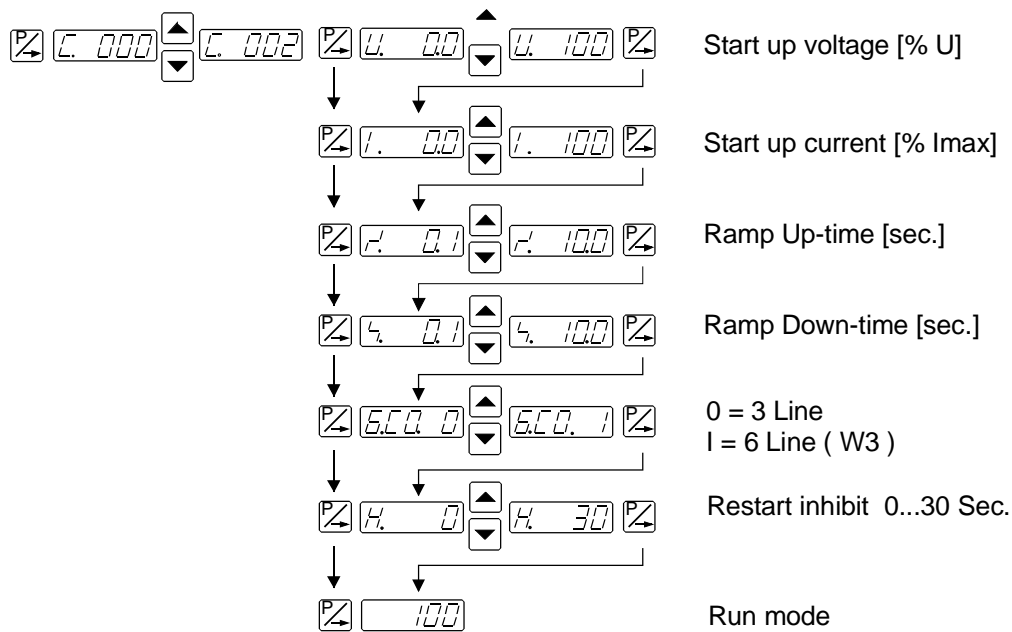

8.1 Display peak current value (in % of I_{max})

Code 005

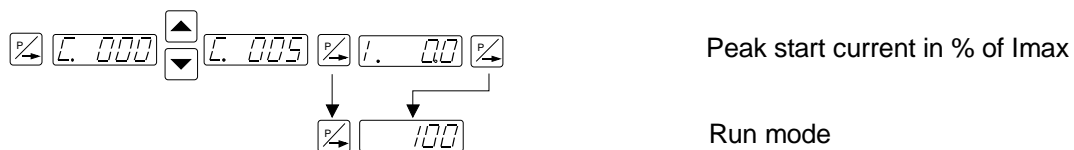

8.2 Save parameter settings

Code 143

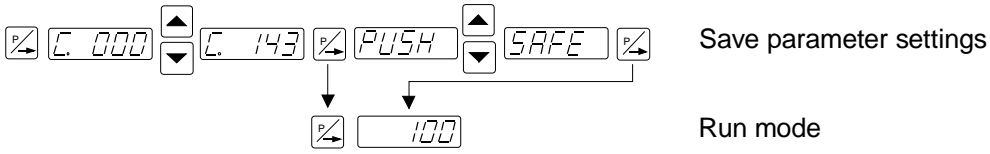

8.3 Recall parameters

Code 210

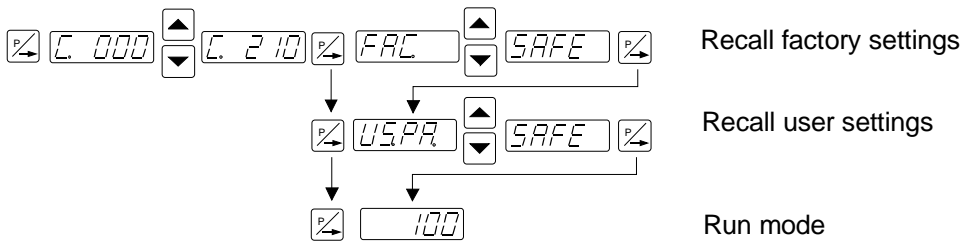

9.0 Connections

Schematic

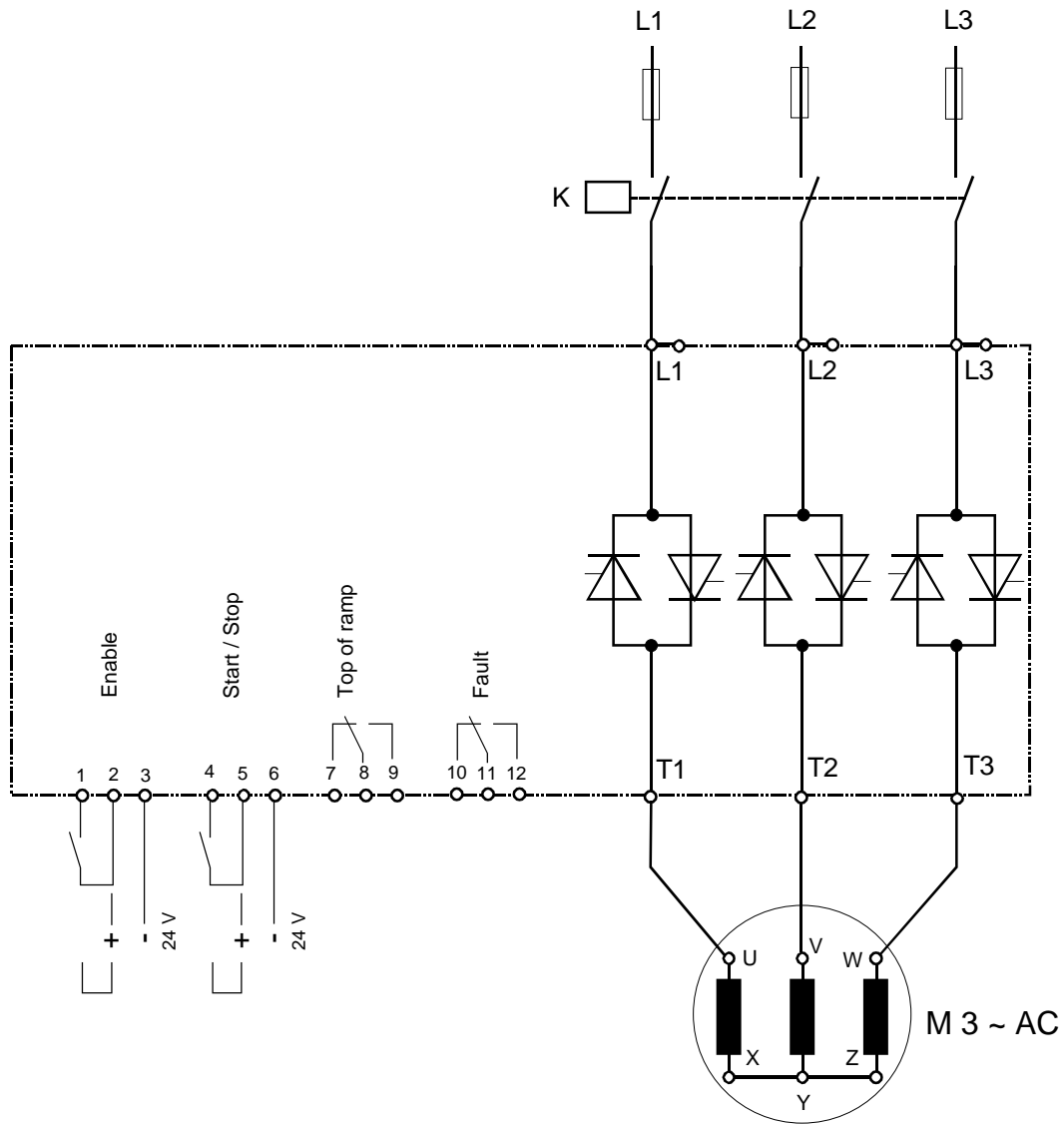

Connections

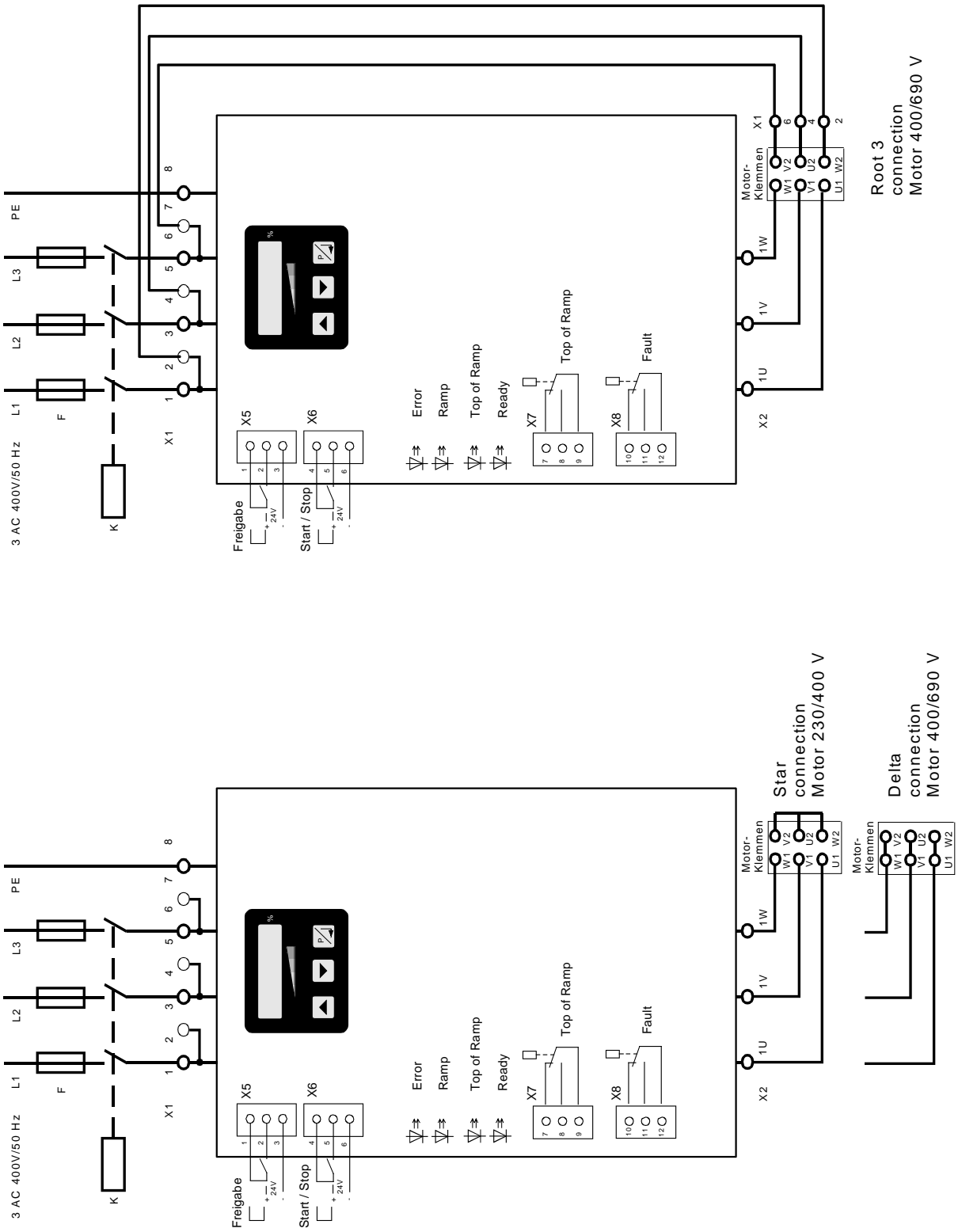

10.0 Dimensions / views

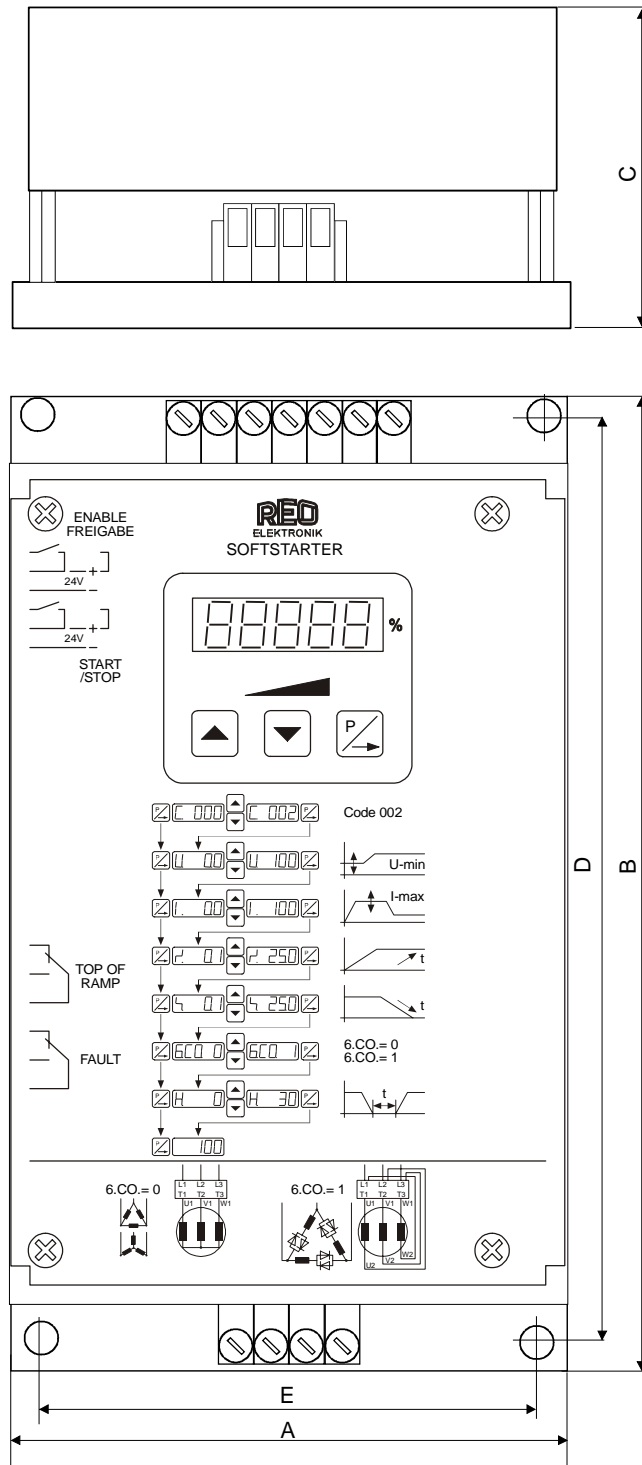

Type	A	B	C	D	E
SAG M300 11	150	300	150	280	130
SAG M300 23	200	300	165	280	180
SAG M300 32	200	300	165	280	180
SAG M300 45	216	300	220	280	195
SAG M300 63	216	300	220	280	195
SAG M300 75	216	300	220	280	195