

Thyristor control unit for use with vibratory feeder units

The REOVIB 506 range of control units are suitable for powering vibratory feeders which have a mechanical vibrating frequency which is the same as, or double that of mains frequency. The adjustment of feeder throughput is achieved by using a triac with phase angle control. The setpoint for the feeder throughput can be derived from a potentiometer. The set point range can be adjusted to suit the feeder unit by using trimmers (see "effects of trimmers Umin/Umax").

The units can operate with feeders which have a mechanical vibrating frequency 50 Hz or 100 Hz, ie 3000/6000 vibs/min (for 60 Hz mains supply this would be 60 Hz or 100 Hz, ie 3600/7200 vibs/min). The vibrating frequency is determined internally. An enable input is provided on terminals 1 and 2 for power free switching of the output (eg from a PLC).

To prevent surges when the unit is switched on, a soft starter is provided. This soft starter becomes effective with all switchings (mains "ON", enable "ON") and with set point adjustment. The semiconductors are protected against short-circuit current by an internal short-circuit fuse.

The output voltage of the unit is fed back internally and compared with the adjusted set point in a regulating device. Deviations which may be caused by mains variations or load changes are adjusted correspondingly.

The unit is supplied in a simple to install modular housing which is suitable for DIN rail mounting (EN 50022-35). The terminals have safety covers, according to VBG 4 standards.

Technical data

Type REOVIB 506	50606
Supply voltage	230 V, + 6 % / - 10 %, 50/60 Hz
Output voltage	0 ... 220 V
Output current	0,5 ... 2 A
Frequency	3000/6000 vibs./min (switchable)
Set point source	Potentiometer 10 kΩ
Enable input	Contact / 12...24 V, DC signal voltage Ri 10 kΩ
Ambient operating temperature	0...45 °C
Dimensions (h x w x d)	74 x 45 x 125 mm
Protection	IP 00
Other standards	IEC 801-2, IEC 801-4, EN 50081-1, VBG 4



Specified Use

The units described herein are electrical controllers for installation in industrial plant. They are designed for power adjustment to resistive and inductive loads.

Dimensions drawing

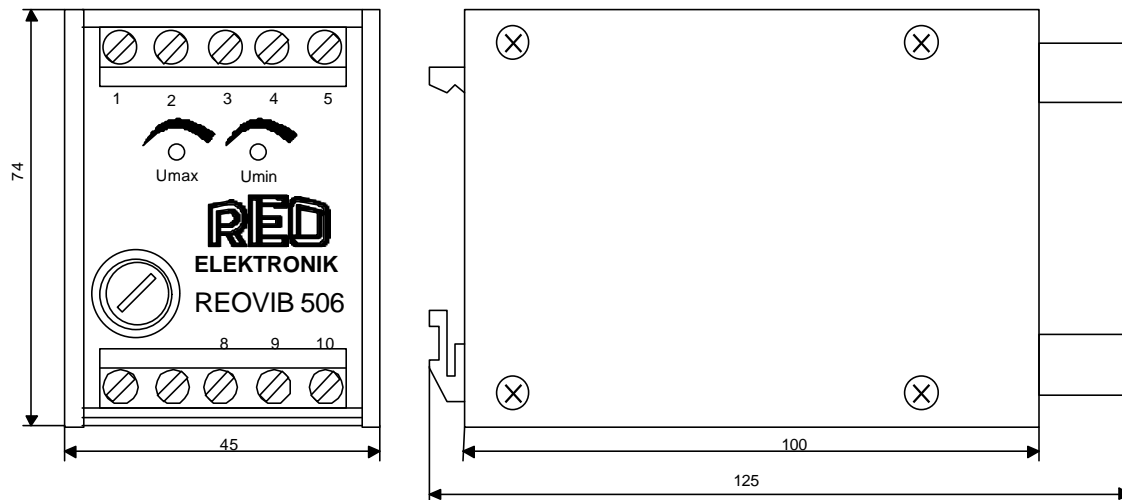

Ordering code: REOVIB 506

ID-No. 50606

Technical Safety Information for the User

This description contains the necessary information for the correct application of the product described below. It is intended for use by technically qualified personnel.

Safety Instructions

The following instructions are provided for the personal safety of operators and also for the protection of the described product and connected equipment.



Warning!

Hazardous Voltage.
 Failure to observe can kill, cause serious injury or damage.

- Isolate from mains before installation or dismantling work, as well as for fuse changes or post installation modifications.
- Observe the prescribed accident prevention and safety rules for the specific application.
- Before putting into operation check if the rated voltage for the unit conforms with the local supply voltage.
- Emergency stop devices must be provided for all applications. Operation of the emergency stop must inhibit any further uncontrolled operation.
- **The electric connections must be covered!**
- **Earth connection must be checked for safe function after assembly!**

Connection drawing and Settings

The switch-over of the mechanical vibrating frequency and the effect of the control input inhibit/enable are realised with the jumpers S1 and S2. To do this, it is necessary to remove the left side cheek of the enclosure.



Attention!
 This input is at mains potential!

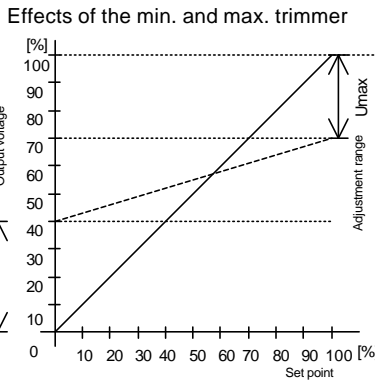
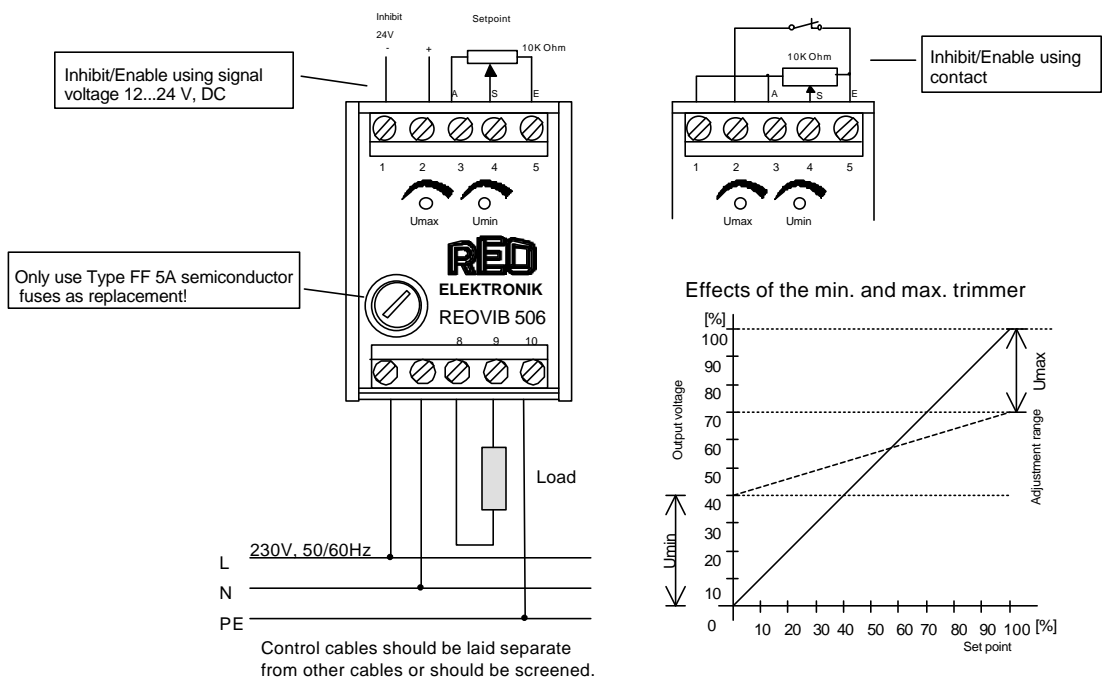

Control cables should be laid separate from other cables or should be screened.

Adjustment:

- Connect controller according to diagram.
- Adjust setpoint to minimum and inhibit unit.
- Switch on mains supply and enable unit.
- Slowly increase the setpoint to maximum and monitor the load condition (if possible measure the voltage and current).
- On reaching maximum, limit the output with trimmer U_{max} and then set the minimum set point value with trimmer U_{min} .

