

REOVIB MFS 168

Frequency Controller for Vibratory Feeders

Overview



Panel mounting Version IP20



Enclosed IP 54





Feeder frequency can be adjusted irrespective of the supply frequency.
 All settings are made externally using a LED display and touch panel.
 Constant feed rate unaffected by supply voltage changes.
 Versions available with integrated track-control or constant amplitude control, which also incorporates automatic natural frequency search (resonance).
 Enable input (Start / Stop), status relay (output active/not active).
 Enclosed IP 54 or panel mounting IP 20

Technical Data:

Supply voltage	115 / 240 V, +/- 10%, 50/60 Hz
Output	0...100 / 0... 205 V, 8 A
Output frequency	30...140 Hz
Enable input	Contacts or 24 V, DC
Track control Sensor	24 V, PNP (100 mA)
Status relay (On-Off)	Change over contacts(250 V, 1 A)
Operating temperature	0...45 °C
Storage temperature	-10...+80 °C
Recommended fuse	16 A Circuit Breakers with type D characteristics for use with high inrush currents

Display and Controls



-  Increase value
-  Decrease value
-  Go back
-  Program mode or confirmation

Instructions:





Menus are used for changing settings. The different parameters are selected by entering a code.
 All adjustments are made by first pressing the P key, followed by selecting the entry code, using the cursor keys.

Settings

Pressing the cursor key for a short time causes a unit increment/decrement, holding down for a longer time gives changes in tens of units.

Setting changes are saved upon leaving the menu or automatically if a key is not pressed for 60 seconds.

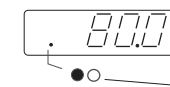
Running Messages

-  Enable ON
-  Track full
-  Set point in %
Timer running
-  Stop using "0" key

Setting	Range	Code	Factory setting	Menu code	Fault messages
Amplitude	0... 100 %	A.	0 %	000, 002	Possible reasons: Feeder too large, frequency too low for fitted coil, air gap too wide.
Maximum output voltage	50...100 %	P	100 %.	096, 008	
Vibrating frequency	30...140 Hz	F.	100 Hz	096, 008	
Soft start	0... 4 Sec.	/.	0.1 Sec.	096	Short circuit on output side
Soft stop	0... 4 Sec.	\.	0,1 Sec.	096	Possible reason: Faulty winding (coil)
External set point source	0 / 1	E.S.P.	0	003	
Set point potentiometer	0 / 1	POT.	0	003	
Set point 0(4)... 20 mA	0 / 1	4.20		003	Input voltage too high
Coarse/fine control	0 / 1	2.SP.	0	003	Reasons: Supply voltage too high or back EMF from the coil.
Invert enable	0 / 1	-En.	0	003	
Switch-on time delay	0... 15 Sec.	I.	5 Sec.	167	Sensor time-out expired
Switch-off time delay	0... 15 Sec.	I.	5 Sec.	167	
Invert sensor	0 / 1	-SE.	0	167	
Activate sensor time out	0 / 1	E.	0	167	
Sensor time out time	30... 240 Sec.	E.E.	5 Sec.	167	
Activate regulation control	0 / 1	ACC.	180 Sec.	167	
Proportional characteristic	0...100	P.A.	40	008	
Integral characteristic	0... 5	I.A.	5	008	
Frequency control ON	0 / 1	A.F.C.	0	008	
Save user settings	PUSH.			143	
Restore factory settings		FAC.		210	
Restore user settings		US.PA.		210	
Hide programming menus		Hd.C.		117	

Fault messages can be cancelled by pressing the P key or switching the controller OFF and ON again.

Plugging and unplugging of controller while under a load may cause damage and void warranty.

No code number is required to change feeder throughput: pressing the P key twice will call up the set point display.

Code 000 Feeder throughput set point

Setting feeder throughput

P P R 00

▲

▼

P R 1000 P

Feeder throughput 0...100 %

P 1000

Normal running

! Protection

The internal capacitors cause a current inrush when the supply is first switched on. This can cause false tripping of in-line circuit breakers, especially when several units are turned on simultaneously. Therefore, slow protectors, such as circuit breakers with type D characteristics should be used.

Safety Instructions

This description contains the necessary information for the correct application of the product described below. It is intended for use by technically qualified personal.

Qualified personnel are persons who, because of their training, experience and position as well as their knowledge of appropriate standards, regulations, health and safety requirements and working conditions, are authorised to be responsible for the safety of the equipment, at all times, whilst carrying out their normal duties and are therefore aware of, and can report, possible hazards (Definition of qualified employees according to IEC 364)



Warning!

Hazardous Voltage

Failure to observe can kill, cause serious injury or damage

Isolate from mains before installation or dismantling work, as well as for fuse changes or post installation modifications.

Observe the prescribed accident prevention and safety rules for the specific application.

Before putting into operation check if the rated voltage for the unit conforms with the local supply voltage.

Emergency stop devices must be provided for all applications. Operation of the emergency stop must inhibit any further uncontrolled operation.

Electrical connections must be covered.

The earth connection must be checked, for correct function, after installation.



Installation

Check !	<p>Are the supply, feeder coil and controller input voltages correct ?</p> <p>Is the controller adequately rated for the rated power of the feeder ?</p> <p>What is the vibrating frequency of the feeder ?</p>
<p>Connect the unit in accordance with the wiring instructions and ensure that earthing is correct !</p>	
! Tip	<p>New units are factory set (see table for settings).</p> <p>For units with unknown settings, first recall the factory settings using Menu C 210 FAC..</p>
External Setpoint.	<p>When an external set point source is used select Menu C 003 E.S.P. = I and if a potentiometer is used select Pot = I.</p> <p>To set the minimum vibration level, select E.S.P. = 0, adjust the vibration level with the cursor keys and then select E.S.P. = I.</p>
	<p>The specific settings for the system can be saved using Menu C 143 US.PA. (recalled using C 210 US.PA).</p> <p>Menus can be hidden by selecting C 117 Hd.C.= 1.</p>

Code 003 Function settings

Run mode

0 = Set point using display
1 = external set point 0...+10 V ON

0 = external set point 0...+10 V
1 = external 4...20 mA

0 = 0...10 V / 0(4)...20 mA
1 = Potentiometer

0 = Track control
1 = Coarse/fine control with two setpoints

0 = Enable
1 = Invert enable

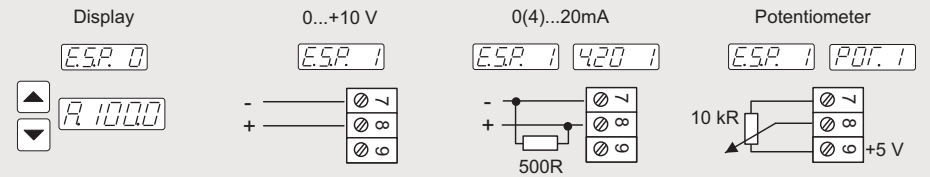

Internal using display panel keys
External set point 0...+10 V, 0(4)...20 mA

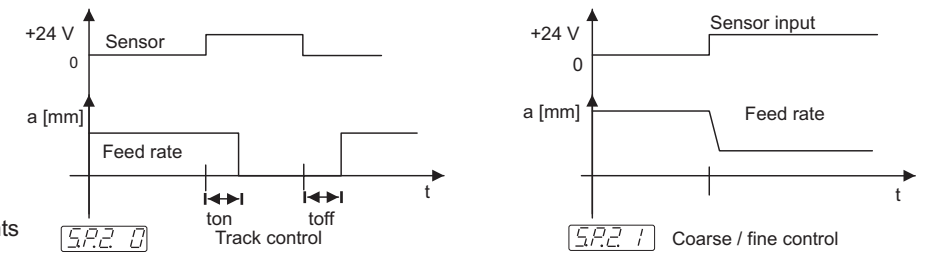

Track control or Coarse / fine control with two feeder speeds.

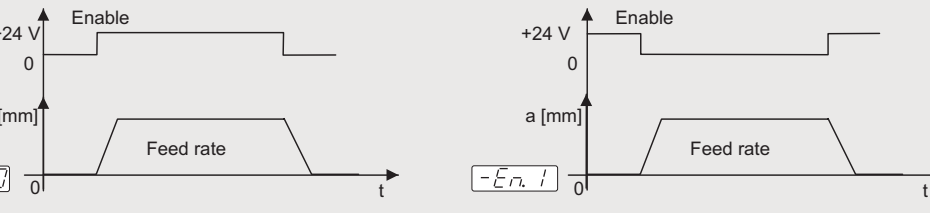

+24 V signal or closed contacts give enabled output
+24 V signal or closed contacts inhibit output.

Code 096 Feeder

Run mode

Feed rate 0...100 %

Maximum limit 100...5 %

Vibrating frequency [Hz]

Soft start 0...5 Sec.

Soft stop time 0...5 Sec.

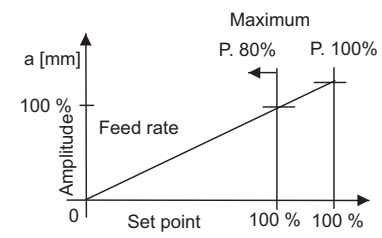
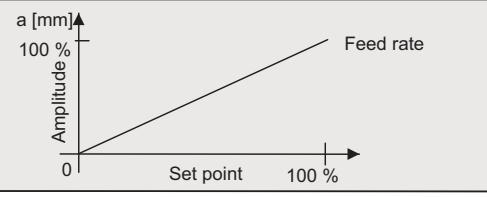

Limiting the maximum feed rate.
Internal limiting of the setpoint can be adjusted from 0...100%.

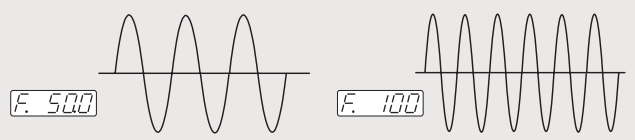

The vibrating frequency depends on the mechanical design of the feeder **Important!**
The incorrect frequency can cause damage to the feeder coils.

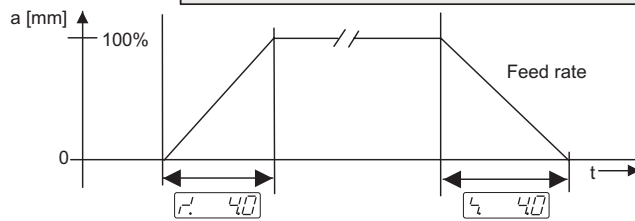

The time ramps used when the feeder is switch on or off.

Set point input
Sensor input
Enable input
Maximum feed rate
Vib. frequency
Soft start / stop

<p>Code C 167 Track control</p> <p>P <code>C. 000</code> <code>C. 167</code> P</p>		<p>Setting the ON and OFF time delays.</p>	<p>Time delays</p>	
<p>P <code>1. 00</code> <code>1. 50</code> P Switch on time delay 0...15 Sec.</p> <p>P <code>0. 00</code> <code>0. 50</code> P Switch off time delay 0...15 Sec.</p>		<p>Invert sensor input.</p>		<p>Sensor</p>
<p>P <code>-5E. 0</code> <code>-5E. 1</code> P Invert sensor function I = inverted</p> <p>P <code>EE. 0</code> <code>EE. 1</code> P 0 = Activity timer enabled I = Activity timer disabled</p> <p>P <code>E. 180</code> <code>E. 240</code> P E. = Sensor-time-out time [sec]</p> <p>P <code>1000</code> Run mode</p>	<p><code>EE. 0</code> not active <code>EE. 1</code> active</p>	<p>Sensor monitoring active. The output is switched ON when no components are seen during the elapsed time setting.</p>	<p>Sensor Monitoring</p>	
<p>Code 143 Save parameter settings</p>	<p>P <code>C. 000</code> <code>C. 143</code> P</p> <p>P <code>PUSH</code> <code>SAFE</code> P Save parameter settings <code>▲</code> All parameter settings are saved</p> <p>P <code>1000</code> Run mode</p>		<p>Save the parameter settings.</p>	<p>Service</p>
<p>Code 210 Recall parameters</p> <p>P <code>C. 000</code> <code>C. 210</code> P</p> <p>P <code>FAC</code> <code>SAFE</code> P Recall factory settings <code>▲</code> Recall factory settings</p> <p>P <code>USPR</code> <code>SAFE</code> P Recall user parameters <code>▲</code> Recall settings saved under C 143</p> <p>P <code>1000</code> Run mode</p>	<p>Reset to delivered state..</p> <p>Recall the parameters previously stored under C 143.</p>			
<p>Code 117 Hide menus</p> <p>P <code>C. 000</code> <code>C. 117</code> P</p> <p>P <code>HdC. 0</code> <code>HdC. 1</code> P I = Menus not visible <code>HdC. 1</code> Parameter settings cannot be accessed, only the set point can be changed <code>HdC. 0</code> Parameter menus can be opened</p> <p>P <code>1000</code> Run mode</p>	<p>Hide programming menus.</p>			

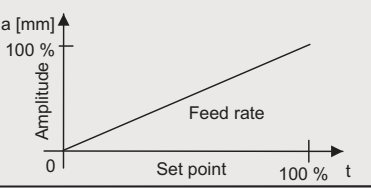
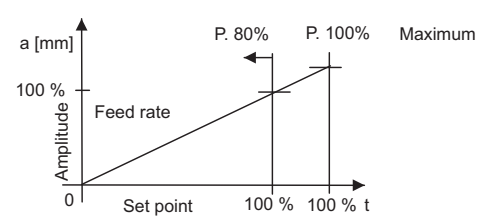
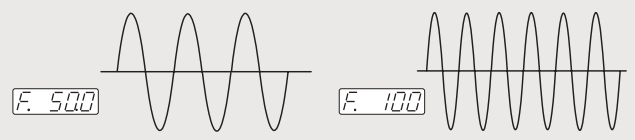
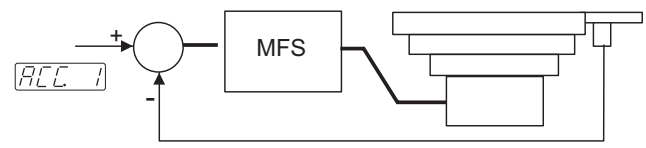
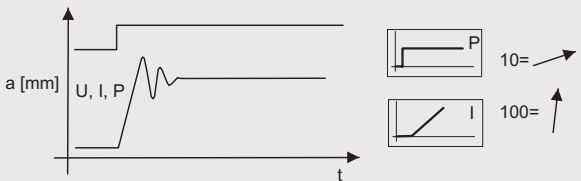
Code 008 Regulation				
<p>P C 000 ▲ C 008 P</p> <p>P R 00 ▼ R 100 P Feed rate 0...100 %</p> <p>P P 1000 ▲ P 900 P Maximum limit 100...5 %</p> <p>P F 500 ▼ F 480 P Vibrating frequency [Hz]</p> <p>P ACC 0 ▲ ACC 1 P Switch on regulation 0 = Controlling (without sensor) I = Regulation (with sensor)</p> <p>PR 10 ▲ PR 10 P Regulation parameter proportional characteristic (circuit gain)</p> <p>IR 10 ▼ IR 10 P Regulation parameter integral characteristic (damping of swing gradient)</p> <p>REC 0 ▲ P Automatic frequency control 0 = OFF I = ON</p> <p>RES ▲ Start frequency search</p> <p>P 1000 Run mode</p>	 	<p>Limiting the output voltage i.e. feed rate, for example to prevent the coil hammering. The set pint range remains at 0...100%.</p>	Maximum feed rate	
		<p>The vibrating frequency setting is determined by the type of feeder.</p>	Vib. frequency	
		<p>Regulation is selected to give constant amplitude even if the load on the feeder varies widely. An accelerometer is required for providing the feedback signal.</p>	Regulation	
		<p>Influences the regulation characteristics such as the response time and restricts the feeder from "hunting".</p>	Regulation param's	
	<p>ACC 0 f = fixed ACC 1 f = f resonance</p> <p>▲ Key starts the automatic resonant frequency search</p>	<p>Automatic frequency adjustment to resonance condition.</p>	Automatic frequency search.	

An acceleration sensor, type SW11 has to be fitted to the feeder for constant amplitude control. Care must be taken in the method of mounting to ensure that the fixtures are solid, provide the correct orientation and do not flex under vibration.

Manual setting of the vibrating frequency:

It is important to have a low set point setting (e.g. 30 %) because upon reaching resonance it is possible that a high amplitude will be induced, even with a low output voltage, thus increasing the risk of the coil "hammering". To determine the resonant frequency, an analogue, effective value, current measuring instrument, such as a moving iron meter, must be connected to the output. Resonant frequency has been reached when there is maximum amplitude and minimum output current .

Automatic frequency search (regulation mode only).

- * Put set point at zero.
- * Select regulation mode (Menu C 008, Parameter ACC = I).
- * The optimum, vibrating frequency of the feeder is determined by initiating the frequency search (Menu C 008, Parameter, select A.F.S. and press any cursor key). Return the controller back to normal running mode after the resonant frequency has been found.

Connections
Surface mounting version
IP 54
Old ID# 616821
New ID# 616748

Standard Version
Cables for input and output power supply
Track sensor; 5-pin DIN connector
Amplitude sensor; 4-pin DIN connector
An Additional cord grip can be fitted for the enable or status signals.

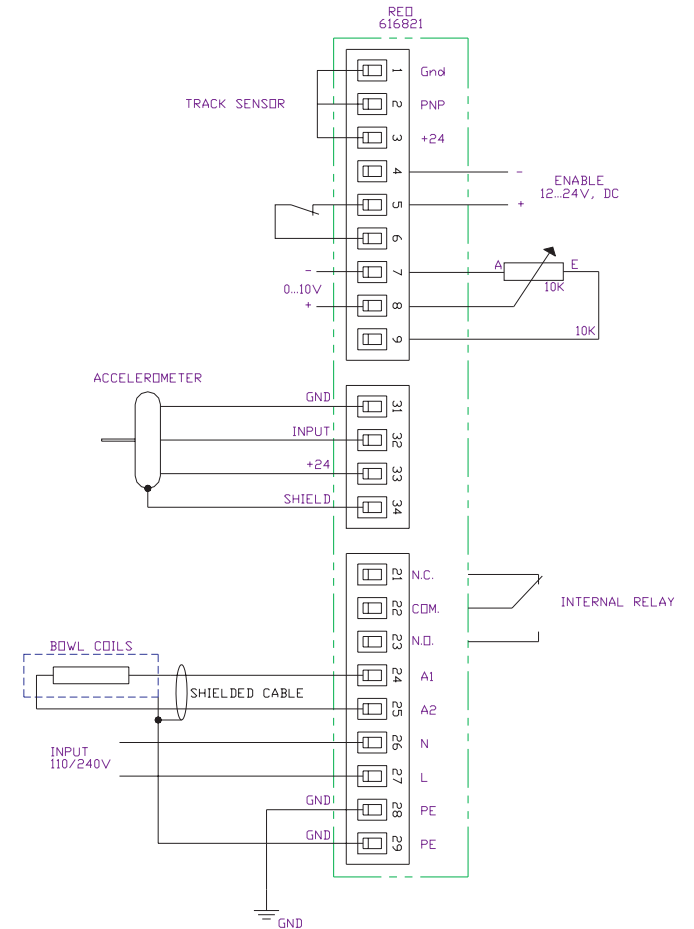
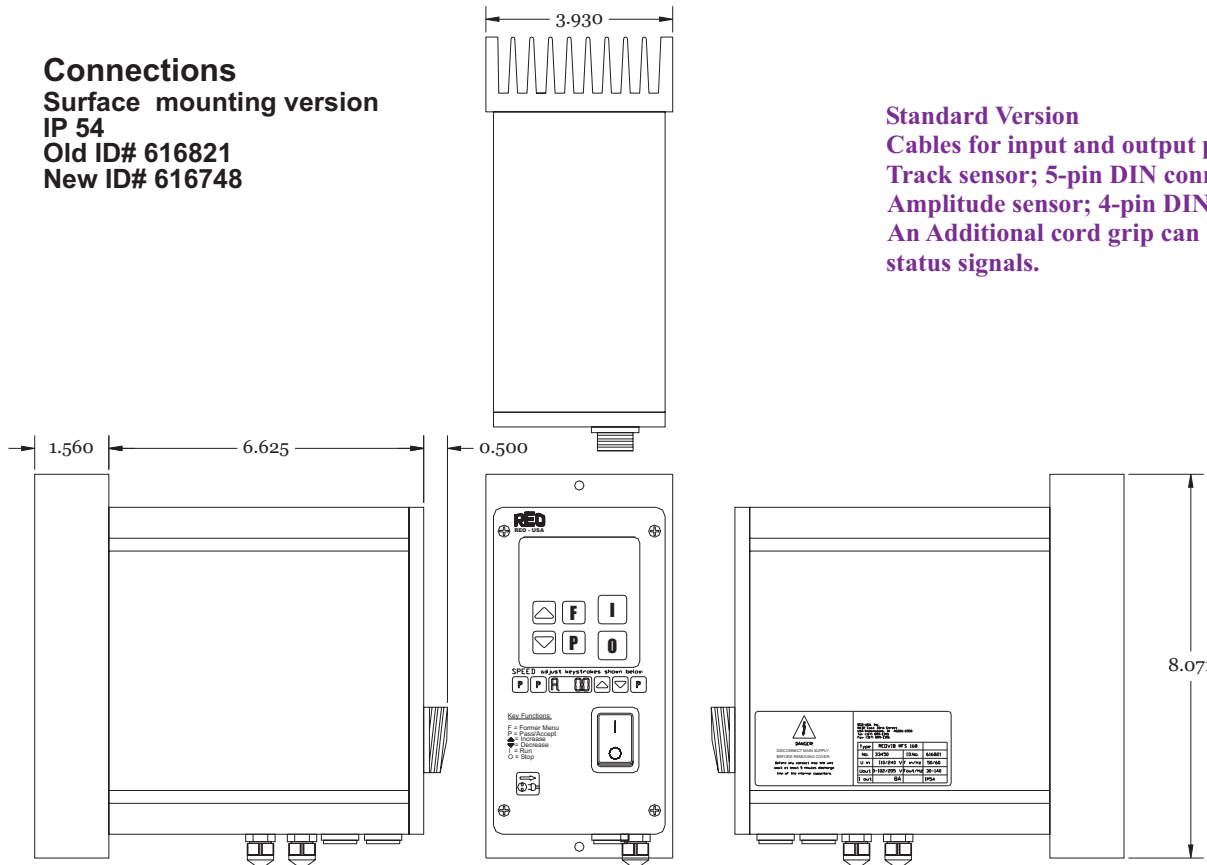

Frequency Sensor:

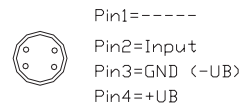

Track Sensor:

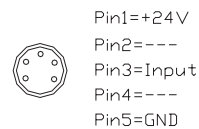

Ordering Codes for connectors:

Track control: 5-pin sensor plug 090105
Accelerometer: 4-pin sensor plug 090104

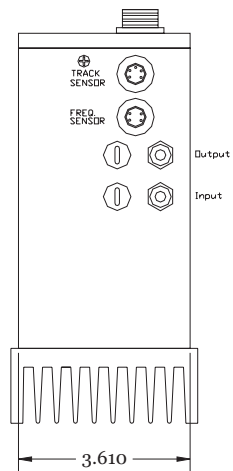

Connections

Panel mounting version

IP 20

ID# 616832

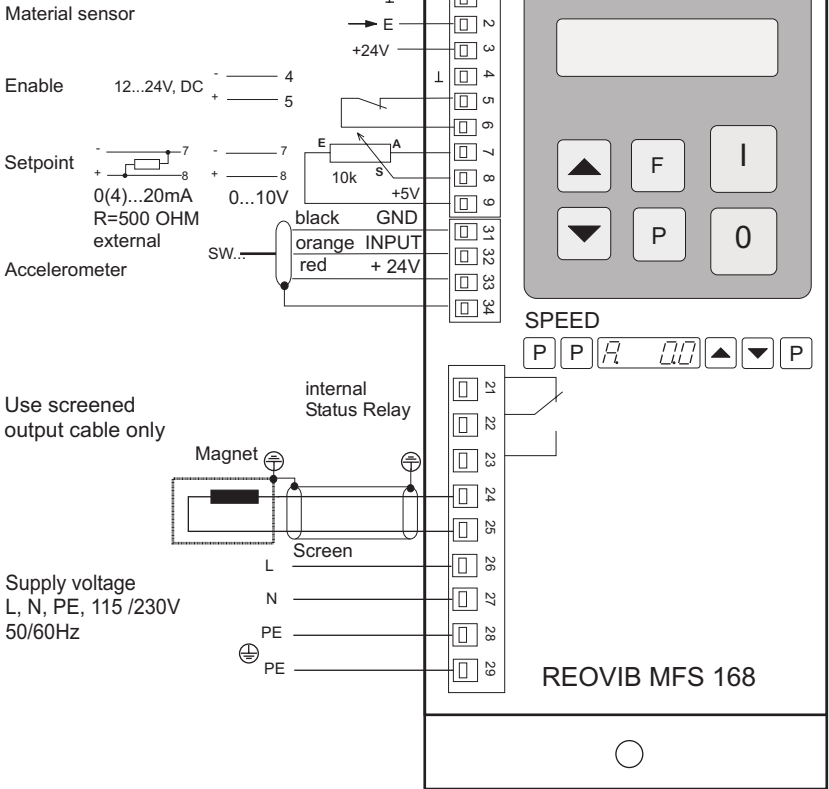

Dimensions

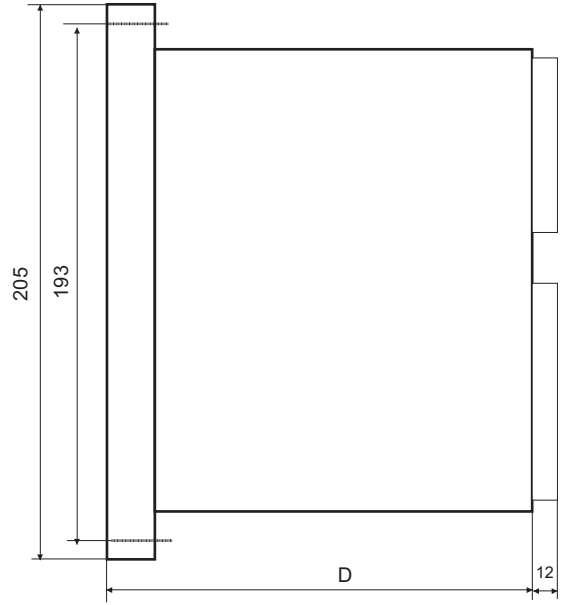
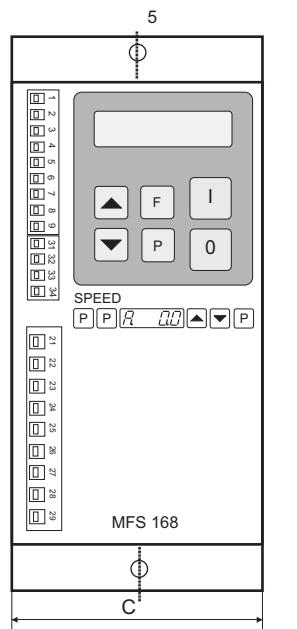
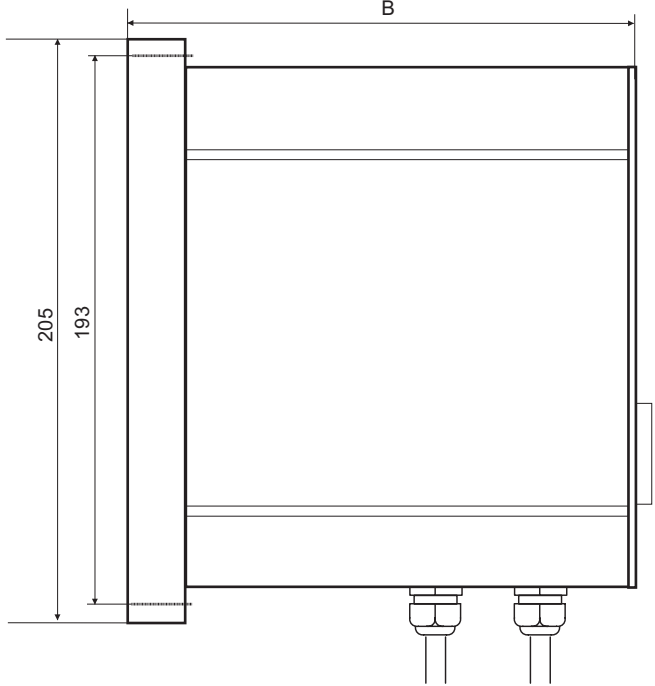
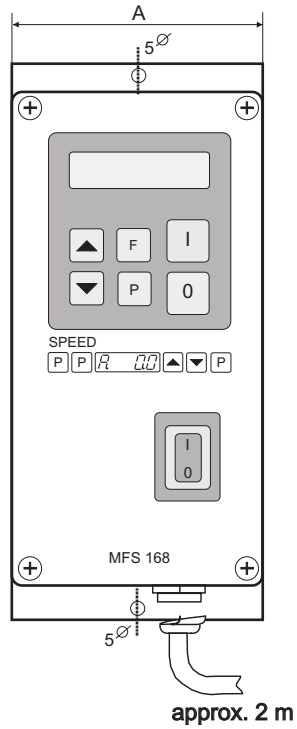

[mm]	3A	6A	8A
A	90	90	100
B	140	186	204
C	94	94	104
D	132	175	195

! When a set point potentiometer is connected select Menu C 003 Parameter E.S.P. = 1 and POT. = 1!

